

CLARKE[®]

weld



140A MMA INVERTER WELDER

MODEL NO: MMA140A

PART NO: 6012161

OPERATION & MAINTENANCE INSTRUCTIONS



ORIGINAL INSTRUCTIONS

GC0522 - Rev 1

INTRODUCTION

Thank you for purchasing this CLARKE MMA (Arc) Welder. Before attempting to operate the machine it is essential that you read this manual thoroughly and carefully follow all instructions given. In doing so you will ensure the safety of yourself and that of others around you, and you can also look forward to the welder giving you long and satisfactory service.

When unpacking, any damage or deficiency should be reported to your CLARKE dealer immediately.

PRINCIPLES OF THE MACHINE

MMA (Arc) welding uses a coated consumable electrode (stick) to lay the weld, therefore an additional welding torch kit is not required. The arc melts the core of the electrode to produce drops of molten metal (weld pool) that cool to create the welded joint. Because of the versatility and simplicity of MMA welding, it requires less skill and is used primarily to weld iron and steel (including stainless steel, but nickel and copper can also be welded using this method.

MAIN DESIGN FEATURES

ARC-FORCE	automatically increases the current to prevent the electrode sticking when operating with a short arc length.
HOT START	increases the welding current at the beginning of the welding process.
ANTI-STICK	the electrode can be easily withdrawn without it becoming damaged.
VOLTAGE REDUCTION SAFETY DEVICE (VRD)	reduces open circuit voltage when not in use to prevent accidental injury

INVENTORY

The items supplied include the following:

- 1 x MMA Inverter Welder
- 1 x Torch Cable with Electrode Holder
- 1 x Earth Clamp & Cable
- 1 x Combination Wire Brush / Hammer
- 1 x Instruction Manual

SAFETY PRECAUTIONS FOR ALL TYPES OF WELDING



WARNING: AS WITH ALL MACHINERY, THERE ARE CERTAIN HAZARDS INVOLVED WITH THEIR OPERATION AND USE. EXERCISING RESPECT AND CAUTION WILL CONSIDERABLY LESSEN THE RISK OF PERSONAL INJURY. HOWEVER, IF NORMAL SAFETY PRECAUTIONS ARE OVERLOOKED, OR IGNORED, PERSONAL INJURY TO THE OPERATOR MAY RESULT.

FAILURE TO FOLLOW THESE RULES MAY RESULT IN SERIOUS PERSONAL INJURY.

GENERAL PRECAUTIONS

BURN PREVENTION

Wear protective clothing - gauntlet gloves designed for use in welding, apron, and protective shoes. Button shirt collar and pocket flaps and wear cuffless trousers to avoid entry of sparks and slag. Wear helmet with safety goggles or glasses with side shields underneath, appropriate filter lenses or plates (protected by clear glass). This is a **MUST** for welding (and chipping) to protect the eyes from radiant energy and spatter. Replace cover glass when broken, pitted, or spattered. Avoid oily greasy clothing. A spark may ignite them. Hot metal should never be handled without gloves. First aid facilities and a qualified first aid person should be available unless medical facilities are close by for immediate treatment of flash burns of the eyes and skin burns. Ear plugs should be worn when working overhead or in a confined space. A hard hat should be worn when others work overhead. Flammable hair preparations should not be used by persons intending to weld or cut.

NOTE: ALL protective wear incl. masks & head shields **MUST** comply with PPE Regulation (EU) 2016/425.

TOXIC FUME PREVENTION

Severe discomfort, illness or death can result from fumes, vapours, heat, or oxygen enrichment or depletion that welding (or cutting) may produce. Prevent them with adequate ventilation. **NEVER** ventilate with oxygen. Lead-, cadmium-, zinc-, mercury- and beryllium-, bearing materials, when welded (or cut) may produce harmful concentrations of toxic fumes. Adequate local exhaust ventilation must be used, or each person in the area as well as the operator must wear an air-supplied respirator. For beryllium, both must be used. Metals coated with or containing materials that emit toxic fumes should not be heated unless coating is removed from the work surface, the area is well ventilated, or the operator wears an air-supplied respirator. Work in a confined space only while it is being force ventilated and, if necessary, while wearing an air-supplied respirator. Vapours from chlorinated solvents can be decomposed by the heat of the arc (or flame) to form PHOSGENE, a highly toxic gas, and other lung and eye irritating products. The ultraviolet (radiant) energy of the arc can also decompose trichloroethylene and

perchloroethylene vapours to form phosgene. DO NOT WELD where solvent vapours can be drawn into the welding atmosphere or where the radiant energy can penetrate to atmospheres containing even minute amounts of trichloroethylene or perchloroethylene.

FIRE AND EXPLOSION PREVENTION

Causes of fire and explosion are:

1. Combustibles reached by the arc, flying sparks, hot slag or heated material;
2. Short circuits.

BE AWARE that flying sparks or falling slag can pass through cracks, along pipes, through windows or doors, and through wall or floor openings, out of sight of the goggled operator.

To prevent fires and explosion: keep equipment clean and operable, free of oil, grease, and (in electrical parts) of metallic particles that can cause short circuits. If combustibles are in the area, do NOT weld. Move the work if practicable, to an area free of combustibles.

Avoid working in paint spray rooms, dip tanks, storage areas, ventilators. If the work cannot be moved, move combustibles away from sparks and heat; or protect against ignition with suitable fire- resistant covers or shields.

Walls, ceilings, and floor near work should be protected by heat resistant covers or shields. Fire watcher must be standing by with suitable fire extinguishing equipment during and for some time after welding or cutting if:

1. appreciable combustibles (including building construction) are within 10m.
2. appreciable combustibles are further than 10m, but can be ignited by sparks.
3. openings (concealed or visible) in floors or walls can expose combustibles to sparks.
4. combustibles adjacent to walls, ceilings, roofs or metal partitions can be ignited by radiant or conducted heat.

After work, check that area is free of sparks, glowing embers and flames. An empty container that held combustibles or that can produce flammable or toxic vapours when heated, must never be welded on or cut, unless the container has first been cleaned. This includes a thorough steam or caustic cleaning (or a solvent or water washing, depending on the combustible's solubility) followed by purging and inerting with nitrogen or carbon dioxide, and using protective equipment.

Water filling just below the working level may substitute for inerting.

A container with unknown contents should be cleaned (see paragraph above). Do NOT depend on sense of smell or sight to determine if it is safe to

weld or cut. Hollow castings or containers must be vented before welding as they can explode.

In explosive atmospheres, never weld or cut where the air may contain flammable dust, gas, or liquid vapours.

ELECTRIC ARC WELDING

Comply with precautions in above and this section. Arc welding, properly done, is a safe process but a careless operator invites trouble. The equipment carries high currents at significant voltages. The arc is very bright and hot. Sparks fly, fumes rise, ultraviolet and infrared energy radiates and work pieces are hot. The wise operator avoids unnecessary risks and protects himself and others from accidents.

BURN PROTECTION

The welding arc is intense and visibly bright. It's radiation can damage eyes, penetrate lightweight clothing, reflect from light coloured surfaces and burn the skin and eyes. Skin burns resemble acute sunburn, those from gas - shielded arcs are more severe and painful.

DON'T GET BURNED! FOLLOW ALL SAFETY PRECAUTIONS!

PROTECTIVE CLOTHING

Wear long sleeved clothing (particularly for gas shielded arc) in addition to gloves, apron and strong shoes. As necessary, use additional protective clothing such as leather jacket or sleeves, flameproof apron, and fire-resistant leggings. Avoid outer garments of untreated cotton. Bare skin protection: Wear dark substantial clothing, Button collars closed to protect the chest and neck and button any pockets to prevent entry of sparks.

EYE AND HEAD PROTECTION

Protect eyes from exposure to arc. NEVER look at an electric arc without protection. Welding helmet or shield containing an appropriate filter plate (Please refer to the section 'Welding Shield'). Place over face before striking arc. Protect filter plate with a clear cover plate. Cracked or broken helmet or shield should NOT be worn; radiation can pass through to cause burns.

Cracked, broken, or loose filter plates must be replaced IMMEDIATELY. Replace clear cover plate when broken, pitted, or spattered. WE SUGGEST you wear flash goggles with side shields under the helmet, to give some protection to the eyes should the helmet not be lowered over the face before an arc is struck. Looking at an arc momentarily with unprotected eyes (particularly high intensity gas-shielded arc) can cause a retinal burn that may leave a permanent dark area in the field of vision. Before welding whilst wearing contact lenses, seek advice from your optician.

PROTECTION OF NEARBY PERSONNEL

For production welding, a separate, well vented room or enclosed bay is best. In open areas, surround the operation with low reflective, non-combustible screens or panels. Allow for free air circulation, particularly at floor level. Provide face shields for all persons who will be looking directly at the weld. Others working in the area should wear flash goggles. Before starting to weld, make sure that screen or bay doors are closed.

TOXIC FUME PREVENTION

Comply with all precautions above.

FIRE AND EXPLOSION PREVENTION

Do not overload arc welding equipment. It may overheat cables and cause a fire. Loose cable connections may overheat or flash and cause a fire. Never strike an arc on a cylinder or other pressure vessel. It creates a brittle area that can cause a violent rupture or lead to such a rupture later under rough handling.

SHOCK PREVENTION

Exposed live conductors or other bare metal in the welding circuit, or in unearthed, electrically-LIVE equipment can fatally shock a person whose body becomes a conductor. DO NOT STAND, SIT, LIE, LEAN ON, OR TOUCH a wet surface when welding, without suitable protection.

PROTECTION FOR WEARERS OF ELECTRONIC LIFE SUPPORT DEVICES (PACEMAKERS).

Magnetic fields from high currents can affect pacemaker operation. Persons wearing pacemakers should consult with their doctor before going near arc welding or spot welding operations.

PROTECTION AGAINST SHOCK

Keep your body and clothing dry. Never work in damp area without adequate insulation against electric shock. Stay on a dry duckboard or rubber mat when dampness or sweat can not be avoided. Sweat, sea water, or moisture between body and an electrically LIVE part - or earthed metal - reduces the body surface electrical resistance, enabling dangerous and possibly lethal currents to flow through the body.

EARTHING THE EQUIPMENT

When arc welding equipment is earthed according to the National Electrical Code and the workpiece is earthed, a voltage may exist between the electrode and any conducting object.

Examples of conducting objects include, but are not limited to, buildings, electrical tools, work benches, welding power source cases, workpieces, etc. Never touch the electrode and any metal object unless the welding power

source is off. When installing, connect the frames of each unit such as welding power source, control, work table, and water circulator to the building earth. Conductors must be adequate to carry earth currents safely. Equipment made electrically LIVE by stray current may shock, possibly fatally. Do not EARTH to electrical conduit, or to a pipe carrying ANY gas or a flammable liquid such as oil or fuel.

CABLES

Frequently inspect cables for wear, cracks and damage. IMMEDIATELY REPLACE those with excessively worn or damaged insulation to avoid possibly lethal shock from bared cable. Cables with damaged areas may be taped to give resistance equivalent to original cable. Keep cable dry, free of oil and grease and protected from hot metal and sparks.

TERMINALS AND OTHER EXPOSED PARTS

Terminals and other exposed parts of electrical units should have insulating covers secured before operation.

SAFETY DEVICES

Safety devices such as interlocks and circuit breakers should not be disconnected or shunted out. Before installation, inspection, or service of equipment, shut OFF all power and remove line fuses (or lock or red-tag switches) to prevent accidental turning ON of power. Do not open power circuit or change polarity while welding. If, in an emergency, it must be disconnected, guard against shock burns, or flash from switch arcing. Always shut OFF and disconnect all power to equipment. A power disconnect switch must be available near the welding power source.

PREPARATION OF THE WORKING AREA

The working area must be sufficiently spacious, not humid, and well-ventilated as to avoid any fumes which develop from the welding process and from incidental material adhering to the pieces to be welded (oils, paints, tars...) which may cause danger to the operator.

Avoid welding tanks which may contain flammable residuals.



WARNING: ELECTRIC SHOCK CAN BE FATAL. A PERSON QUALIFIED IN FIRST AID SHOULD ALWAYS BE PRESENT IN THE WORKING AREA. IF PERSON IS UNCONSCIOUS AND ELECTRIC SHOCK IS SUSPECTED, DO NOT TOUCH THE PERSON IF HE OR SHE IS IN CONTACT WITH THE WELDER OR CABLES. DISCONNECT THE WELDER FROM THE POWER SOURCE AND THEN USE FIRST AID. DRY WOOD, OR OTHER INSULATING MATERIAL CAN BE USED TO MOVE CABLES, IF NECESSARY, AWAY FROM THE PERSON.

ADDITIONAL PRECAUTIONS FOR MMA WELDING

1. ALWAYS ensure that there is full free air circulating around the outer casing of the machine and that the louvres are unobstructed.
2. A welding arc can seriously damage your eyes. Both operator and spectators must ALWAYS use a proper welding face shield or helmet with suitable filter lenses. Proper gloves and working clothes should be worn at all times.
3. ALWAYS remove all flammable materials from the welding area.
4. NEVER remove any of the panels unless the machine is disconnected from the supply and never use the machine with any of the panels removed.
5. NEVER use or store in a damp environment. DO NOT EXPOSE TO RAIN.
6. NEVER attempt any electrical or mechanical repair unless you are a qualified technician. If you have a problem with the machine contact your local CLARKE dealer.
7. ALWAYS keep a fire extinguisher handy (Dry Powder, CO₂ or BCF, NOT Water).
8. NEVER continue to weld, if, at any time, you feel even the smallest electric shock. Stop welding IMMEDIATELY and DO NOT attempt to use the machine until the fault is diagnosed and corrected.
9. NEVER allow the earth cable or torch to become wrapped around the operator or any person in the vicinity.

A comprehensive range of CLARKE safety equipment for use when welding is available from your local dealer.







Consideration should be given to shielding the supply cable of permanently installed welding equipment, in metallic conduit or equivalent. Shielding should be electrically continuous throughout its length.

The shielding should be connected to the welding power source so that good electrical contact is maintained between the conduit and the welding power source enclosure.

The welding equipment should be routinely maintained according to the manufacturer's recommendations. All access and service doors and covers should be closed and properly fastened when the welding equipment is in operation. The welding equipment should not be modified in any way except for those changes and adjustments covered in the manufacturer's instructions. In particular, the spark gaps of arc striking and stabilizing devices should be adjusted and maintained according to the manufacturers recommendations.

SAFETY SYMBOLS

The following symbols may be displayed on the machine.

	<p>Read this instruction booklet carefully before use.</p>		<p>Do not expose to rain.</p>
	<p>Wear eye protection</p>		<p>Recycle unwanted materials instead of disposing of them as waste. All tools, accessories and packaging should be sorted, taken to a recycling centre and disposed of in a manner which is compatible with the environment.</p>
	<p>Wear protective gloves</p>		
	<p>Wear a dust mask</p>		

ELECTRICAL CONNECTION

CONNECTING TO MAINS POWER

NOTE: This welder is earthed and must only be connected to the mains with an earth connection. Do not attempt to use it without one.

- This welder is not supplied with a mains electrical plug because at full capacity it will draw far too much power for a normal domestic 230V mains plug and socket. This welder must not be fitted with a standard 13A UK plug.
- A high current 230V mains socket or terminal must be installed by a qualified and accredited professional electrician. A 16A socket and plug conforming to IEC 60309 is recommended.
- A non-socketed mains connection also requires welder connection by a qualified and accredited professional electrician. However, a socketed connection is safer and is recommended so the welder can be safely isolated when necessary. If directly wired to the mains, a double pole, double throw isolator switch must be fitted.
- The welder must be connected using a circuit protected by an RCD.
- Please refer to the Specification for details of the maximum current required by this welder.

If in any doubt, do not attempt to connect or use this welder until a professional electrician has been consulted.

ENVIRONMENTAL RECYCLING POLICY



Through purchase of this product, the customer is taking on the obligation to deal with the WEEE in accordance with the WEEE regulations in relation to the treatment, recycling & recovery and environmentally sound disposal of the WEEE.

In effect, this means that this product must not be disposed of with general household waste. It must be disposed of according to the laws governing Waste Electrical and Electronic Equipment (WEEE) at a recognised disposal facility.

If disposing of this product or any damaged components, do not dispose of with general waste. This product contains valuable raw materials. Metal products should be taken to your local civic amenity site for recycling of metal products.

MMA/ARC WELDING

PREPARATION

To prepare the machine for ARC welding it is important that you follow the procedure below.

1. Making sure that the ON/OFF switch, located on the rear panel is in the OFF position, connect the welding leads as follows:

- Work clamp lead to the (-) Negative terminal.

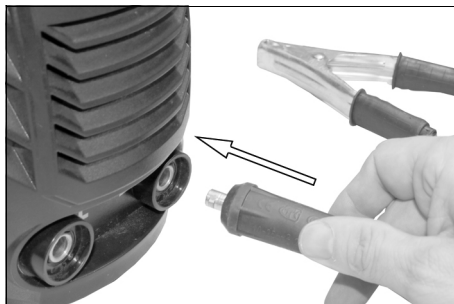

- Welding rod holder lead to the (+) Positive terminal



2. Select the appropriate welding rod and insert it into the welding rod holder.

ROD DIAMETER	MATERIAL THICKNESS
1.6 mm	1.0 - 2.0 mm
2.5 mm	1.0 - 2.0 mm
3.2 mm	2.0 - 5.0 mm

3. Attach the work clamp to the workpiece as close as possible to the area being welded. Clean with a wire brush where necessary to ensure the connection is as clean as possible.

- Switch ON using the switch located on the rear panel.
 - The display on the front panel will come on and show the current setting in amps.
- If the machine stops at any time and the thermal overload indicator comes ON, the thermal overload device has intervened. Wait until the welder has cooled sufficiently (the thermal overload indicator goes out) before restarting work.

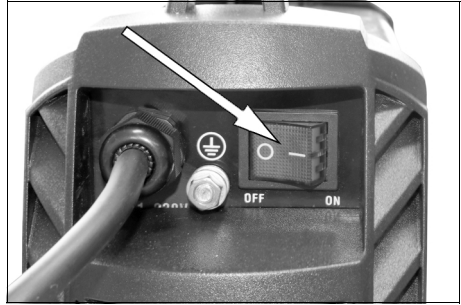

- Set the required current using the current selector.
 - With practice you will gain a feel for the correct current setting for different welding rod thicknesses.



VRD-VOLTAGE REDUCTION DEVICE

The VRD is a safety feature that It is also known as “Anti-shock”.

Its function is to lower the open circuit voltage across the output terminals to a safe 12V when the welder is not in use.

As soon as the welder is used (a load of 200 ohms or less is detected), the voltage will increase to the full output to enable welding to commence.

The “VRD” will only turn the output of the welder back to a reduced output state of 12 volts once the electrode is removed from the work piece or if the resistance across the output rises above 200 ohms.



If you wish to turn off this feature, set the VRD switch on the front panel to OFF. We recommend that you leave it switched ON.

STRIKING THE ARC - WELDING



WARNING: WHEN WELDING ALWAYS ENSURE THERE IS ADEQUATE VENTILATION IN THE WORK AREA AS THE WELDING PROCESS GIVES OFF TOXIC FUMES.



WARNING: WELDING ARCS PRODUCE HARMFUL UV/IR LIGHT WHICH CAN SERIOUSLY DAMAGE YOUR EYES. ALWAYS USE A WELDING HELMET WITH A SUITABLE FILTER THAT CONFORMS TO CURRENT STANDARDS.

WARNING: NEVER LOOK AT THE ARC WITHOUT A SUITABLE WELDING MASK

WARNING: PROTECT BYSTANDERS BY USING WELDING SCREENS/ CURTAINS.

The most difficult aspect of the arc welding process, particularly for beginners, is that of striking an arc. We strongly recommend that you practice on some pieces of scrap metal to get the feel of the operation, before you start on an actual welding job.

1. Hold the electrode about 10 mm from the work and at an angle of about 70° to 80° to the work surface; take care not to accidentally touch the workpiece until you are ready to start.
2. Holding the welding mask close-up to your face, give a short stroke with the electrode on the workpiece. As soon as the arc is primed, withdraw the electrode from the workpiece to leave a tiny gap of around 1.5mm (1/16"). The current will flow across the gap with a crackling noise and a brilliant arc. Continue to weld in one direction, maintaining the small gap as you go.

NOTE: When you prime the arc, be sure to withdraw the electrode swiftly to leave the 1.5 mm. gap, otherwise the electrode will weld itself to the workpiece. If this occurs give the electrode a short sharp jerk to free it and, if necessary, prime the arc again. If you cannot free the electrode, switch the machine off immediately and free it. Take care the electrode will get red hot very quickly and will be capable of burning through welding gloves.

3. At the end of the run, just lift the electrode away from the workpiece.
4. Inspect the job carefully. Any slag forming on the surface should be chipped away with a chipping hammer or pick. ALWAYS wear your safety goggles when chipping away slag.

WELDING PITFALLS

The arc welding technique is an acquired skill and requires considerable practice before perfect results are obtained. The diagrams below will help to explain the pitfalls in your technique and how to overcome them.

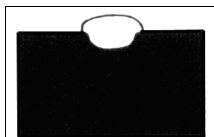

ARC TOO SHORT

This causes irregular masses of weld to be deposited, with slag contamination on an uneven surface.

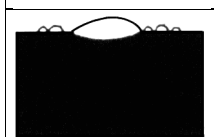

ARC TOO LONG

This causes poor penetration resulting in a weak weld with excessive spatter and porosity. Surface of the weld is rough and the arc makes a hissing sound

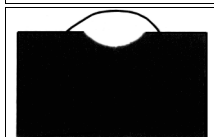

ELECTRODE MOVED TOO SLOWLY

This causes a very wide and heavy deposit which overlaps at the sides. It is wasteful both in terms of time and electrode use.



ELECTRODE MOVED TOO QUICKLY

This causes poor penetration with a 'stringy' and incomplete weld deposit. Slag is very hard to remove.

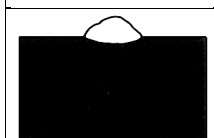

CURRENT TOO LOW

This causes poor penetration and causes the electrode to stick to the workpiece too readily. Also results in a very irregular and high weld deposit. Slag is very hard to remove.

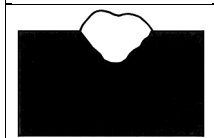

CURRENT TOO HIGH

This causes excessive penetration with spatter and deep pointed crater. It may also cause holes to be burned in the workpiece.

Burns electrodes very quickly.

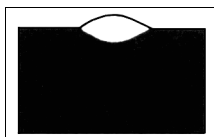

THE PERFECT WELD

With the correct combination of arc length, current regulation, inclination and speed of the electrode, you will, with practice, produce the perfect weld.

This should be regular with uniform ripples and no slag contamination. The arc will make a steady crackling sound.

TROUBLESHOOTING

DEFECT	CAUSES	SUGGESTIONS
Spark will not start	Bad clamp connection. Inverter printed circuit is defective.	Check clamp connection. Contact your nearest CLARKE dealer.
No output voltage	Overheated machine (the red LED should be on).	Wait for thermal cutout to be reset.
	Internal relay has failed.	Contact your nearest CLARKE dealer.
	Inverter printed circuit is defective.	Contact your nearest CLARKE dealer.
Wrong output current	Current selector control is defective.	Contact your nearest CLARKE dealer.
	Low power supply voltage.	Check the mains distribution system.
Porosity of welds	Acid electrode on steel with high sulphur content. Electrode oscillates too much. Workpieces are too far apart. Workpiece being welded is cold.	Use basic electrode. Move edges to be welded closer together. Move slowly at the beginning.
Cracks in weld	Material being welded is dirty (e.g.oil, paint, rust, oxides). Not enough current.	Clean workpiece before welding is an essential method of achieving neat weld beads.
Limited penetration	Low current, high welding rate, reversed polarity. Electrode inclined in position opposite to it's movement.	Ensure operating parameters are regulated and improve preparation of work pieces.
High Sprays	Electrode is too inclined.	Make appropriate corrections.

DEFECT	CAUSES	SUGGESTIONS
Profile defects	Welding parameters are incorrect. Pass rate is not related to operating parameter requirements. Electrode not inclined constantly while welding.	Follow basic and general welding principles.
Arc is unstable	Insufficient current.	Check condition of electrode and earth wire connection.
Electrode melts obliquely	Electrode core is not centred. Magnetic blow phenomenon.	Replace electrode. Connect two earth wires to opposite sites of the work piece.

MAINTENANCE

WARNING: DISCONNECT FROM MAINS BEFORE CLEANING.



WARNING: DO NOT ATTEMPT TO CARRY OUT REPAIRS YOURSELF, UNLESS YOU ARE FULLY COMPETENT, ALL WORK MUST BE CARRIED OUT BY A QUALIFIED TECHNICIAN.

The machine requires very little maintenance other than the following guidelines. Under normal working conditions removing the covers and cleaning with dry compressed air at reduced pressure once a year will be quite sufficient. Cleaning at more frequent intervals is advisable however, if the unit is operating in a dusty and dirty environment.

1. Keep the louvres clean to avoid a build up of dirt and oxides inside the machine, which can reduce machine output.
2. Check all cables periodically for condition and secure. They must be in good condition and not cracked.
3. Always avoid getting particles of metal inside the machine since they could cause short circuits.

RATING PLATE

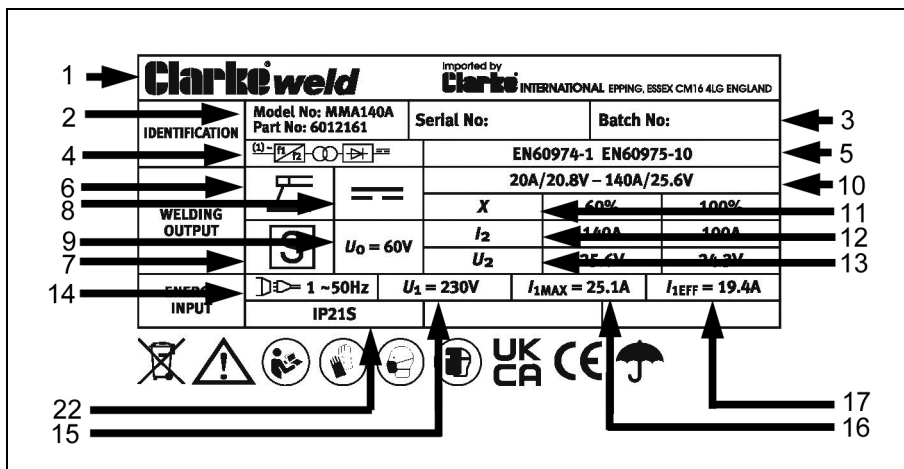

1	Name and address of manufacturer	12	Rated Welding Current Symbol
2	Model Number, / Part Number	13	Conventional Load Voltage Symbol
3	Serial / Batch Number	14	Energy Supply Symbol
4	Welding Power Source	15	Rated Supply Voltage
5	British Standards applied	16	Rated Maximum Supply Current
6	Welding Process Symbol	17	Maximum Effective Supply Current
7	This symbol indicates that the unit is suitable for carrying out welding operations in an environment which has an increased risk of electric shock	18	N/A
8	Welding Current Symbol	19	
9	Rated No-load Voltage	20	
10	Range Of Output	21	
11	Duty Cycle Symbol	22	Degree of Protection

DUTY CYCLE

This welder is covered by regulations EN 60974-1:2018 +A1:2019, / EN 60974-10:2014+A1:2015, where the Duty Cycle (X) is expressed as a percentage of time the machine may be used in a given period for a specified welding current.

i.e. When welding at 140 Amps the machine may be used for 6 minutes (60%) in any 10 minute period,

SPECIFICATIONS

Unpacked Weight (kg)	4.35
Dimensions (l x w x h) (mm)	365 x 130 x 250
Power Supply	230V AC~ 50Hz
Rated Max Input Current (A) I_{1Max} / I_{1eff} (A)	25.1 / 19.4
No Load Voltage (V)	60
Max/Min Welding Current (A)	20A/140A
IP Rating	IP21S
Suitable Electrodes (mm)	1.6 - 3.2

NOTE: The details and specifications contained herein, are correct at the time of going to print. However, CLARKE International reserve the right to change specifications at any time without prior notice.

GUARANTEE

This CLARKE product is guaranteed against faulty manufacture for a period of 12 months from the date of purchase. Please keep your receipt as proof of purchase.

This guarantee is invalid if the product is found to have been abused or tampered with in any way, or not used for the purpose for which it was intended.

Faulty goods should be returned to their place of purchase, no product can be returned to us without prior permission.

This guarantee does not effect your statutory rights.

CONSUMABLES

The following are some of the accessories available from your CLARKE dealer. Please quote the part numbers shown below.

DESCRIPTION	PART NUMBER
1.6 mm Arc Welding Electrodes	3050590
2.5 mm Arc Welding Electrodes	3050594
3.2 mm Arc Welding Electrodes	3050596

ARC ACTIVATED HEADSHIELDS

These highly popular headshields activate instantly when the arc is struck and allow you to have both hands free when welding.

Model	Arc Activated	Grinding function	Solar Powered	Fixed Shade	Flip Up	Part Number
GWH4	✓	✓	✓			6000706
GWH7	✓	✓	✓			6000709
GWH5	✓	✓	✓			6000707
GWH6	✓	✓	✓			6000708
GWH3	✓	✓	✓			6000698
GWH2	✓	✓	✓			6000697
PG4	✓	✓	✓			6000716
HS1				✓	✓	6000700
HSF1				✓	✓	6000705

COMPONENT PARTS

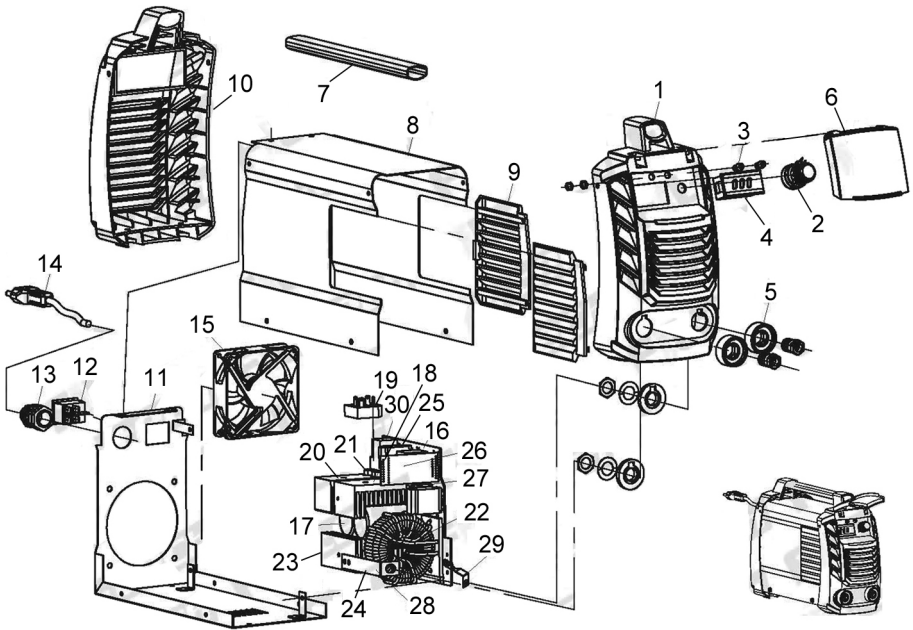

NO	DESCRIPTION	NO	DESCRIPTION
1	Front panel	16	Printed circuit board
2	Potentiometer	17	Capacitor
3	Indicator light	18	Silicon bridge radiator
4	Digital display	19	Silicon bridge
5	Plug	20	IGBT radiator
6	Gauge cover	21	IGBT
7	Handle	22	Main transformer
8	Cover	23	Rectifier radiator
9	Air Vent	24	Rectifier tube
10	Rear panel	25	Driver transformer
11	Machine base	26	Control PCB
12	Power switch	27	CBB
13	Waterproof joint	28	Positive connector
14	Power cable	29	Negative connector
15	Fan assembly	30	Relay

DECLARATIONS OF CONFORMITY



Clarke[®]
INTERNATIONAL

Hemnal Street, Epping, Essex CM16 4LG

DECLARATION OF CONFORMITY

This is an important document and should be retained.

We hereby declare that this product(s) complies with the following statutory requirement(s):

Electromagnetic Compatibility Regulations 2016

Electrical Equipment (Safety) Regulations 2016

The Restriction of the Use of Certain Hazardous Substances in Electrical and Electronic Equipment Regulations 2012

The following standards have been applied to the product(s):

EN 50445:2008, EN IEC 60974-1:2018+A1:2019, EN 60974-10:2014+A1:2015, EN 61000-3-11:2000,

EN 61000-3-12:2011, IEC 61000-4-2:2008, IEC 62321-1:2013, IEC 62321-2:2013, IEC 62321-3-1:2013

EN 62321-3-2:2013, IEC 62321-4:2013+AMD1:2017, IEC 62321-5:2013, IEC 62321-6:2015,

EN 62321-7-1:2015, IEC 62321-7-2:2017, IEC 62321-8:2017.

The technical documentation required to demonstrate that the product(s) meet(s) the requirement(s) of the aforementioned legislation has been compiled and is available for inspection by the relevant enforcement authorities.

The UKCA mark was first applied in: 2021

Product Description: 140 Amp MMA Inverter Welder

Model number(s): MMA140A

Serial / batch Number: n/a

Date of Issue: 24/11/2021

Signed:

J.A. Clarke
Director

DECLARATIONS OF CONFORMITY



Clarke[®]
INTERNATIONAL

Fitzwilliam Hall, Fitzwilliam Place, Dublin 2

DECLARATION OF CONFORMITY

This is an important document and should be retained.

We hereby declare that this product(s) complies with the following directive(s):

2014/30/EU *Electromagnetic Compatibility Directive*

2014/35/EU *Low Voltage Equipment Directive*

2011/65/EU *Restriction of Hazardous substances*

The following standards have been applied to the product(s):

EN 50445:2008, EN IEC 60974-1:2018+A1:2019, EN 60974-10:2014+A1:2015, EN 61000-3-11:2000,

EN 61000-3-12:2011, IEC 61000-4-2:2008, IEC 62321-1:2013, IEC 62321-2:2013, IEC 62321-3-1:2013

EN 62321-3-2:2013, IEC 62321-4:2013+AMD1:2017, IEC 62321-5:2013, IEC 62321-6:2015,

EN 62321-7-1:2015, IEC 62321-7-2:2017, IEC 62321-8:2017.

The technical documentation required to demonstrate that the product(s) meet(s) the requirement(s) of the aforementioned directive(s) has been compiled and is available for inspection by the relevant enforcement authorities.

The CE mark was first applied in: 2021

Product Description: 140 Amp MMA Inverter Welder

Model number(s): MMA140A

Serial / batch Number: n/a

Date of Issue: 24/11/2021

Signed:

J.A. Clarke
Director

A SELECTION FROM THE VAST RANGE OF

Clarke®

QUALITY PRODUCTS



AIR COMPRESSORS

From DIY to industrial, Plus air tools, spray guns and accessories.

GENERATORS

Prime duty or emergency standby for business, home and leisure.

POWER WASHERS

Hot and cold, electric and engine driven - we have what you need

WELDERS

Mig, Arc, Tig and Spot. From DIY to auto/industrial.

METALWORKING

Drills, grinders and saws for DIY and professional use.

WOODWORKING

Saws, sanders, lathes, mortisers and dust extraction.

HYDRAULICS

Cranes, body repair kits, transmission jacks for all types of workshop use.

WATER PUMPS

Submersible, electric and engine driven for DIY, agriculture and industry.

POWERTOOLS

Angle grinders, cordless drill sets, saws and sanders.

STARTERS/CHARGERS

All sizes for car and commercial use.

PARTS & SERVICE: 0208 988 7400

Parts Enquiries

Parts@clarkeinternational.com

Servicing & Technical Enquiries

Service@clarkeinternational.com

SALES: UK 01992 565333 or Export 00 44 (0)1992 565335

Clarke® INTERNATIONAL Hemnall Street, Epping, Essex CM16 4LG
www.clarkeinternational.com